

INVITATION to EXHIBIT



窓と暮らしを
彩るインテリア
Interiors Using Windows To Enrich Daily Living.

The 33rd

JAPANTEX 2014

11/12 (wed) ~ 14 (fri)

Tokyo Big Sight / East Hall

10:00~17:00

<http://www.japantex.jp/>

ホーム・ビル&インテリアWEEK

Joint exhibition with Japan Home & Building Show

Organized by Nippon Interior Fabrics Association / Japan Management Association

The 33rd

JAPANTEX 2014

The Largest International Interior Trend Show in Japan.



Theme

"Interiors Using Windows To Enrich Daily Living."

Windows are like screens projecting a smile-filled way of life. A full range of interior elements enriches daily life and high-quality, light-drenched spaces. Interior décor makes every day happier and brighter.

Only JAPANTEX Can Offer Such Diverse Sponsor Projects.

● Theme Booths

Theme-zone exhibits linked to the overall show theme.



● Interior design talk sessions and seminars

Numerous projects for business-applicable seminars and talk sessions with leading creative designers.

● Business Partnerships

Venues provided for business expansion among exhibitors.

● Exhibitor Presentations

At the seminar venue, exhibitors introduce visitors to their recommended and new products and to their companies and technologies.



Why a Joint Exhibition?

Getting a stronger message across to related industries

The Japan Home & Building Show targeted the housing and architectural industries while JAPANTEX concentrated on interior. Combining the two strengthens the message they convey to a wider field.

Benefit of Visitors

Holding the two jointly means they cover unsupported area of each other and provide visitors with a full line of products from housing structural components to interior design materials.

Benefit of Exhibitors

Simultaneously holding exhibitions targeting related industries facilitates acquisition of new clients and increases business negotiations by attracting about 40 thousand specialists in housing, architecture, and interior design.

Home, Building & Interior Week Floor Plan



Mutual entry will be allowed.

Japan Home & Building Show 2014 The 33rd JAPANTEX 2014

Japan Home & Building Show 2014

Held this year for the 36th time, the Japan Home and Building Show has a long, achievement-rich history of displaying building materials, domestic equipment, computer-aided design (CAD), and products for design/exterior. It is a special exhibition related to materials, parts, and equipment for all kinds of buildings from detached houses to apartment buildings. Last year, large numbers of representatives from design offices, construction companies, house manufacturers, power builders, general contractors, and subcontractors attended the show.

Advantages of Exhibiting in JAPANTEX

Advantage 1 Popular among Representatives of Many Fields

Huge numbers of people from the interior-design, domestic-architecture, and general- architectural fields attend. Because it is very popular with highly qualified architects, interior coordinators, and interior planners, the show provides excellent opportunities to get to know the latest in interior trends and current design ideas for pleasing spaces. Numerous talk shows by top creative artists and seminars of great business value too are drawing cards.

◆ "Home, Building & Interior Week" Visitors Specification in 2013

	Occupation	JAPANTEX	Japan Home & Building Show	Total
A	Building Owner	273	481	754
	Developer			
	Real Estate Agent			
B	Architecture Design Office	878	1,189	2,067
	Design Office			
C	Builder's Office	628	2,598	3,226
	Home Builder			
D	General Contractor	180	777	957
	Sub Contractor			
	Construction Company			
E	Interior Finishing Store	1,197	604	1,801
	Wallpaper Shop and Tatami Shop			
	Remodeler's Shop			
F	Department Store	1,278	263	1,541
	Mass Merchandiser / DIY Store			
	Interior Specialty Shop			
	Mail-order Business			
	Other Retail			

	Occupation	JAPANTEX	Japan Home & Building Show	Total
G	Building Management	101	193	294
	Building Maintenance			
H	Trading	1,502	2,511	4,013
	Wholesaler			
I	Infrastructure	103	451	554
	Communication/IT			
J	Building Material Manufacturer	2,740	3,625	6,365
	Housing Equipment Manufacturer			
	Interior Manufacturer			
	Other Manufacturer			
K	Public Office/Association	207	468	675
	Hospital/Scholastic Institution/ Communal Facility			
L	Owner	1,256	767	2,023
	Consumer			
	Student			
Visitors from Other Exhibition		2,840		2,840
Total				27,110

Advantage 2 Business Expansion

Visitors are highly satisfied with the way business partnerships and exhibitor presentations promote acquisition of new client, business expansion, and commercial-PR vitalization.

◆ How do you evaluate the effectiveness of exhibiting in this year's show?



Advantage 3 Provides Chances for New Network Building

Because it attracts a whole new level of visitors, holding JAPANTEX and the Japan Home and Building Show together contributes to the creation of broader business networks extending beyond the field of interiors.

◆ How do you think participation in this year's show will affect your future business transactions?

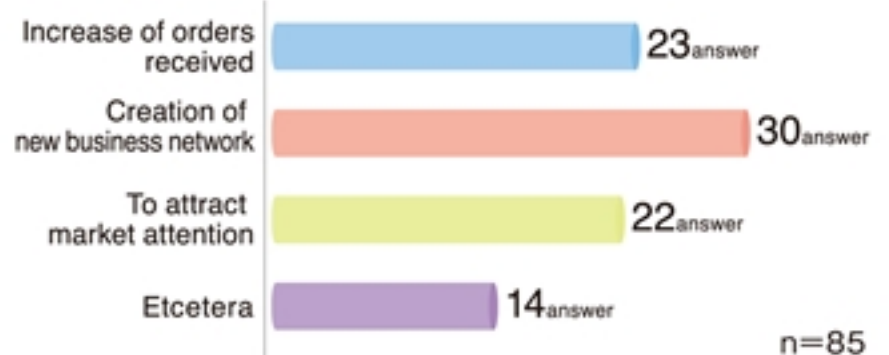

◆ What are your thoughts on combining JAPANTEX with the Japan Home & Building Show?

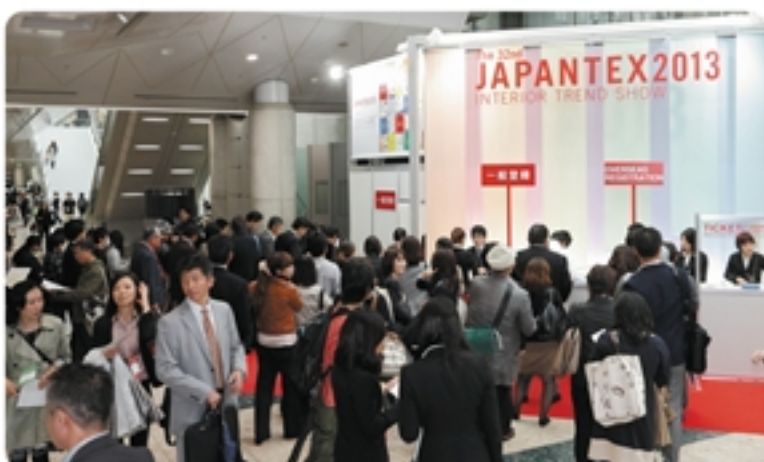
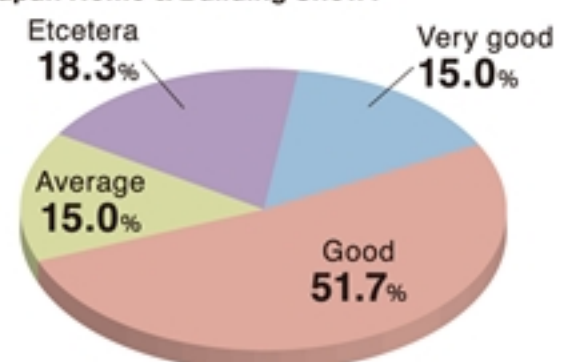

JAPANTEX 2013 Exhibitors List

- A** A Style & TORII DESIGN OFFICE (IFDA)
Abeyoushindou (Tokyo Hyougu Kyouji Naisou Bunkakyoukai)
Acorns Flower Design Studio (IFDA)
ALL JAPAN BEDDING GOODS ASSOCIATION
ANHUI JANTENE HOME TEXTILES CO., LTD.
(CHINA ARTS INTERNATIONAL EXHIBITION CO., LTD.)
Anonimo Design (Theme exhibition)
Anshin Project Japan Inc.
Art Planning Service Co.,LTD (Theme exhibition)
ARTE JAPAN (Theme exhibition)
art-k (Theme exhibition)
Asahi Kasei Trading Co., Ltd.
(JAPAN CARPET MANUFACTURES ASSOCIATION)
Asahi Textile Co.,Ltd (Gifushi Habitat Textile Association)
ASWAN CORPORATION (Theme exhibition)
Azuma Hyouguten
(Tokyo Hyougu Kyouji Naisou Bunkakyoukai)
- B** BAKUMA INDUSTRIAL CO.,LTD
Balmoral International (TEXTILES FRAU PEREZ S.L.)
BELK CO.,LTD
Bikentec Co., Ltd. (IFDA)
Blanc Plan LLC (IFDA)
BRITISH WOOL MARKETING BOARD
(JAPAN CARPET MANUFACTURES ASSOCIATION)
- C** CARPET EXPORT PROMOTION COUNCIL
Carpet Gallery co.,Ltd
Cegi Tekstil Konif San ve Tic Ltd Sti
CHANGSHU QUNYING KNITTING MANUFACTURE CO., LTD.
(CHINA ARTS INTERNATIONAL EXHIBITION CO., LTD.)
CHINA ARTS INTERNATIONAL EXHIBITION CO., LTD.
Chinar International
(CARPET EXPORT PROMOTION COUNCIL)
CLARKE & CLARKE
CLASICA Co., LTD. (Theme exhibition)
Creation bauman japan (Theme exhibition)
- D** DAIICHI HANPU CO.,LTD
DAISEN Ltd.
D'Arc Deco co.,Ltd.
DECORADOR (Theme exhibition)
DECORATORS (IFDA)
Design Club Co., Ltd. (IFDA)
- F** F&H Farhadan OHG. (MEIWA INTERNATIONAL CORP.)
Fill inc.
Form Associates Design (Theme exhibition)
FUJIE TEXTILE CO.,LTD
FUJII DESIGN OFFICE
FUJILIGHT CARPET CO.,LTD.
Fujisawa Corporation Co.,Ltd.
FULLNESS CO.,LTD
Furumaki Hyougu Interiorten
(Tokyo Hyougu Kyouji Naisou Bunkakyoukai)
- G** Gallery Hirota (IFDA)
Gallery Soujiro (IFDA)
Gifushi Habitat Textile Association
Giso Co.,Ltd (Gifushi Habitat Textile Association)
Goyo Shoji Co.,Ltd (Gifushi Habitat Textile Association)
- H** HANGZHOU RUICHANG BEDCLOTHES CO., LTD.
(CHINA ARTS INTERNATIONAL EXHIBITION CO., LTD.)
HASETORA SPINNING CO.,LTD.
(JAPAN CARPET MANUFACTURES ASSOCIATION)
Hideyuki Kobayashi Design Office (IFDA)
HIRAKU SPINNING CO.,LTD.
(JAPAN CARPET MANUFACTURES ASSOCIATION)
Horisyou Co.,Ltd (Gifushi Habitat Textile Association)
HOSOMA-DESIGN
HOTTA CARPET CO.,LTD.
(JAPAN CARPET MANUFACTURES ASSOCIATION)
HUBEI YABI HOME TEXTILE CO., LTD.
(CHINA ARTS INTERNATIONAL EXHIBITION CO., LTD.)
- I** I.D.TANAKA (Tokyo Hyougu Kyouji Naisou Bunkakyoukai)
IICRC JAPAN
(JAPAN CARPET MANUFACTURERS ASSOCIATION)
INTERIOR DECORATION ASSOCIATION OF TOKYO
Interior Jouhoukikaku Ltd.
International Furnishings and Design Association (IFDA)
Ishii Sandayuu Hyouguten
(Tokyo Hyougu Kyouji Naisou Bunkakyoukai)
Ishizuka Hyouguten
(Tokyo Hyougu Kyouji Naisou Bunkakyoukai)
Itoh Hyouguten
(Tokyo Hyougu Kyouji Naisou Bunkakyoukai)
- J** JAPAN CARPET CO.,LTD.
(JAPAN CARPET MANUFACTURES ASSOCIATION)
JAPAN CARPET MANUFACTURERS ASSOCIATION
JAPAN CONSTRUCTION INTERIOR COOPERATIVES
FEDERATION
- J** Japan Interior Architects / Designers' Association (IFDA)
JAPAN INTERIOR DECORATION ASSOCIATION (JIDA)
- K** K Tec Company Ltd.
KAGUMACHI KOUBOU & KAGUMACHI LAB
KAWASHIMA SELKON TEXTILES CO.,LTD
(JAPAN CARPET MANUFACTURES ASSOCIATION)
kawashima selokon textiles co., ltd
KB ENTERPRISES UNITED CO., LTD
(CHINA ARTS INTERNATIONAL EXHIBITION CO., LTD.)
Kida Design (IFDA)
kiji craft (Theme exhibition)
KINKAME SHIGYO CO.,LTD
KINUGAWA CO.,LTD. / KINUGAWA PACK GROUP
Konabe Seiseidou
(Tokyo Hyougu Kyouji Naisou Bunkakyoukai)
KOWA (Theme exhibition)
KURASHIBOKKO
KUWA DESIGN STUDIO
KYOKKO CO., LTD. (Theme exhibition)
KYOKUTO SANKI CO., LTD. (Theme exhibition)
Kyoushindou Inazaki
(Tokyo Hyougu Kyouji Naisou Bunkakyoukai)
- L** La vie au Japon (IFDA)
Lea Lea Enterprise Co.,LTD
(LI PENG ENTERPRISE CO.,LTD)
Li Peng Enterprise CO.,LTD
Life Style Museum INTERIOR HIKAMIYAMA Co., Ltd.
LILYCOLOR CO., LTD. (Theme exhibition)
Living Design Center Co., Ltd.
LUICE.CO.,LTD
Lune d'eau,Co.,LTD
- M** MACHIDA HIROKO ACADEMY Co., Ltd.
MAKEMAN (Theme exhibition)
Marusa Co.,Ltd (Gifushi Habitat Textile Association)
Marusu Suzuki Co.,Ltd (Gifushi Habitat Textile Association)
MEGASOFT Inc
MEGASOFT Inc (Theme exhibition)
MEIWA INTERNATIONAL CORP.
MIHASHI Co., Ltd. (MACHIDA HIROKO ACADEMY Co., Ltd.)
Mihashi Techno-Art Co.,Ltd
(MACHIDA HIROKO ACADEMY Co., Ltd.)
Minamisanriku sewing club
Minamisanriku sewing club
(THE TEXTILE DESIGN ASSOCIATION OF JAPAN)
Modam GmbH
Morisima Souge (Gifushi Habitat Textile Association)
Mortazavi Carpet Group Iran
MURAKAMI CARPET CO.,LTD.
(JAPAN CARPET MANUFACTURES ASSOCIATION)
- N** Nambu Hyouguten
(Tokyo Hyougu Kyouji Naisou Bunkakyoukai)
NaraYamato Co.,Ltd (Mehrali Carpet)
Neo TAPIS inu
NICHIBEI CO.,LTD.
Nihon shinso shibbun co.ltd
NIHON SHORYOKU CO.,LTD.
(JAPAN CARPET MANUFACTURES ASSOCIATION)
NIHONSEIZUKIKOGYO CO.,LTD
NINGBO LIYANG CURTAIN COMPANY LIMITED
(CHINA ARTS INTERNATIONAL EXHIBITION CO., LTD.)
NISSHIKI CO.,INC.
(JAPAN CARPET MANUFACTURES ASSOCIATION)
NISSIN CO.,LTD.
(JAPAN CARPET MANUFACTURES ASSOCIATION)
NITIE CORPORATION
Nobuyuki Design Office Inc. (IFDA)
Noman Terry Towel Mills Ltd.
- O** OHNO INC.
OHNO INC.
(JAPAN CARPET MANUFACTURES ASSOCIATION)
Ohtaka Hyouguten
(Tokyo Hyougu Kyouji Naisou Bunkakyoukai)
OKAZAKI CO., LTD. (Theme exhibition)
Ota Textile Co.,Ltd (Gifushi Habitat Textile Association)
OTSUKA KAGU, LTD. (Theme exhibition)
OZONE LIGHTING ACADEMY
(Living Design Center Co., Ltd.)
- P** Pamposh International
(CARPET EXPORT PROMOTION COUNCIL)
PELMET Co.,Ltd
Pradeep Carpets International
(CARPET EXPORT PROMOTION COUNCIL)
- Q** Q Designs
QINGDAO BAOLI TEXTILES,
EMBROIDERY&DRAWNWORK CO.,LTD.
- R** Risa Braire Co., Ltd. (IFDA)
Rita International
(CARPET EXPORT PROMOTION COUNCIL)
RUNON CO.,LTD.
- S** SAN-ETSU CO.,LTD.
SANGETSU CO.,LTD
Sankyo Co.,Ltd (Gifushi Habitat Textile Association)
SANSAN Co., Ltd.
Segafredo Zanetti Espresso Worldwide Japan, Inc.
SEIREN CO.,LTD
Sekisui House, Ltd, SHIC Plaza Yokohama
(Theme exhibition)
SEKISUI SEIKEI, Ltd.
Senken Shimbun co.,Ltd
Shanghai Revon Trade Co.,Ltd.
SHANDONG QINGZHOU SHUNFA EMBROIDERY CO., LTD.
(CHINA ARTS INTERNATIONAL EXHIBITION CO., LTD.)
SHANGHAI SHANFU TRADING CO., LTD
SHENZHEN RICH SUN TEXTILE CO., LTD.
(CHINA ARTS INTERNATIONAL EXHIBITION CO., LTD.)
Shinohara Obanoyama Design
Shuukoudou (Tokyo Hyougu Kyouji Naisou Bunkakyoukai)
SIESTA International Associates (IFDA)
Sincol
SK Kaken Co.,Ltd
Studio Ma (IFDA)
Suikoudou (Tokyo Hyougu Kyouji Naisou Bunkakyoukai)
Sujata Exports (CARPET EXPORT PROMOTION COUNCIL)
SUMINOE TEXTILE CO.,LTD.
(JAPAN CARPET MANUFACTURES ASSOCIATION)
SUMIYOSHI CO.,LTD.
(JAPAN CARPET MANUFACTURES ASSOCIATION)
SUNCHEMICAL CO.,LTD.
(JAPAN CARPET MANUFACTURES ASSOCIATION)
Sunohara Hyouguten
(Tokyo Hyougu Kyouji Naisou Bunkakyoukai)
SUNROSE CO.,LTD
Suzuki Hyouguten
(Tokyo Hyougu Kyouji Naisou Bunkakyoukai)
- T** TACHIKAWA CORPORATION
TAJIMA, INC.
(JAPAN CARPET MANUFACTURES ASSOCIATION)
Tapié corp. (IFDA)
TEXTILES FRAU PEREZ S.L.
The Joyo Chamber of Commerce and Industry Sansaishi project
The Murakami Shin design o ce (IFDA)
THE TEXTILE DESIGN ASSOCIATION OF JAPAN
THE WOOLMARK COMPANY YD
(JAPAN CARPET MANUFACTURES ASSOCIATION)
TOA CORK CO., LTD.
TOABO MATERIAL CO.,LTD.
(JAPAN CARPET MANUFACTURES ASSOCIATION)
Tokyo Hyougu Kyouji Naisou Bunkakyoukai
TOLI Corporation
TOLI Corporation
(JAPAN CARPET MANUFACTURES ASSOCIATION)
Toray Amtecs Inc.
(JAPAN CARPET MANUFACTURES ASSOCIATION)
TOSO COMPANY, LIMITED
Total Interior Yamamoto
(Tokyo Hyougu Kyouji Naisou Bunkakyoukai)
TOWA SHOKAI (Theme exhibition)
- U** UNIVERS CO.,LTD.
UNIVERSAL TREASURE CO.,LTD
- V** VIUDA DE RAFAEL GANDIA SA
- W** WON ON ONE
WuJiang WeiJiang Textile-Machine Co., Ltd.
- Y** Yamada Hyouguten
(Tokyo Hyougu Kyouji Naisou Bunkakyoukai)
YAMADA SHOMEI LIGHTING CO.,LTD (SANGETSU CO.,LTD)
YAMAMOTO INDUSTRIAL CO.,LTD.
(JAPAN CARPET MANUFACTURES ASSOCIATION)
YAMATOBOU CO.,LTD.
(JAPAN CARPET MANUFACTURES ASSOCIATION)
Yamazaki Hyouguten
(Tokyo Hyougu Kyouji Naisou Bunkakyoukai)
YAYOI CHEMICAL SALES CO.,LTD
YAYOI CHEMICAL INDUSTRY CO.,LTD
(YAYOI CHEMICAL SALES CO.,LTD)
YKK AP Inc.
YONEZAWA-BUSSAN CO.,Ltd
YOSHIDAFUSA ORIMONO CO.,LTD.
(JAPAN CARPET MANUFACTURES ASSOCIATION)
Y's Hands (IFDA)

Outline

Title	ホーム・ビル&インテリアWEEK The 33rd JAPANTEX2014
Theme	窓と暮らしを彩るインテリア (Interiors Using Windows To Enrich Daily Living.)
Organizer	Nippon Interior Fabrics Association (NIF) 6F, Fukuda Bldg., 2-3-23, Hamamatsucho, Minato-ku, Tokyo 105-0013 Japan TEL+81-3-3433-4521 FAX+81-3-3433-7860 http://www.japantex.jp/english Japan Management Association 3-1-22 Shiba-koen, Minatoku, Tokyo 105-8522 Japan http://www.jma.or.jp/en
Date	November 12 (Wed.) - 14 (Fri.), 2014
Opening Hours	10:00~17:00
Venue	TOKYO BIG SIGHT East Hall 1 3-10-1 Ariake, Kotoku, Tokyo 135-0063 Japan Tel:03-5530-1111 http://www.bigsight.jp/english
Support	Ministry of Economy, Trade and Industry (METI), Japan External Trade Organization(JETRO), The Association of the Promotion of International Trade, Japan.
Number of Exhibitors	200
Prospective Visitors	40,000(Home, Building & Interior Week)
Joint Exhibition	ホーム・ビル&インテリアWEEK Japan Home & Building Show 2014
In Conjunction with	The 39th International Healthcare Engineering Exhibition HOSPEX EXHIBITION JAPAN 2014

Buyers find what they want at JAPANTEX (Participation open to exhibitors from all kinds of interior-related organizations.)

Window Treatments	Curtains, Blinds, Screens, Curtain Rail, Upholstery, Decoration Fabrics, Fabrics, etc.
Floor Coverings	Carpets, Rugs, Wooden Flooring, Flooring Materials, Cork Tiles, Plastic Flooring, Tatami Mats, Textile, etc.
Wall Coverings	Wallpaper, Japanese Wall Paper, Paintings, Tiles, Fusuma Paper, Shoji Paper, etc.
Home Fashion	Cushions, Tapestries, Tableware, Upholstery Fabrics, Towels, Bedding, Interior Goods, Picture Frames, Picture Rails, Furniture, Interior Lighting
Technology	Sewing Machines, Glues, Repair Items, Equipment, Software, Printers, etc.
Japanese-Traditional	Fabrics, Japanese Paper, Wooden Products, Lacquer Products, etc.
Interior Publishers	Press, Media
ETC.	Textile design, Textile pattern, etc.

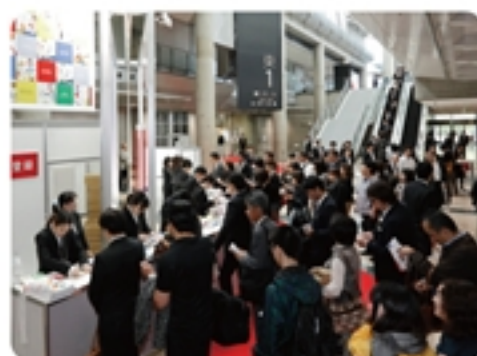
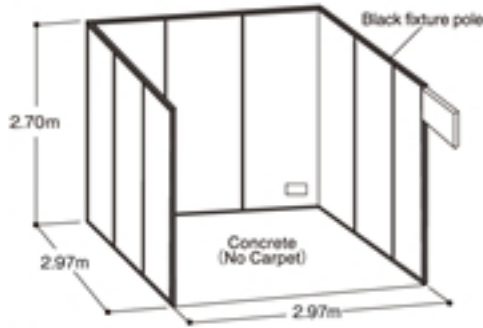

Exhibit Fee

Basic Booth

1 booth (3m×3m=9m²)
= JPY 340,000 (Tax excluded)



Fee includes :

- System wall panels
- Booth number plate
- 300W main electrical power supply
- One electrical power point (a breaker switch only - no outlet)

CAUTION You must install floor covering such as carpets.

5 booth units or more

Raw space only (5 booth units or more) does not provide system wall panels and booth number plate.



Packaged Booth (1-4 booth units)

1 booth (3m×3m=9m²)
= JPY 409,000 (Tax excluded)

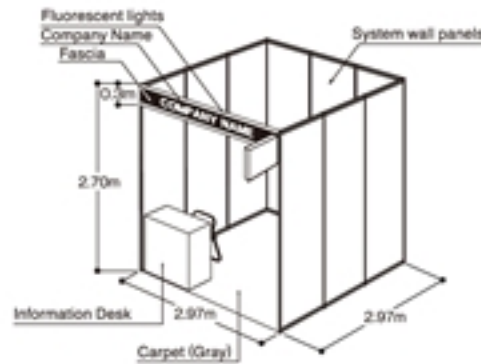

Fee includes :

- System wall panels
- Fascia
- Company name
- Carpet (Gray)
- Two fluorescent lights (40W)
- 300W main electrical power supply
- One power outlet
- One information desk
- One folding chair
- Booth number plate

ex:2booth 2 booth (3m×6m=18m²)
= JPY 791,000 (Tax excluded)

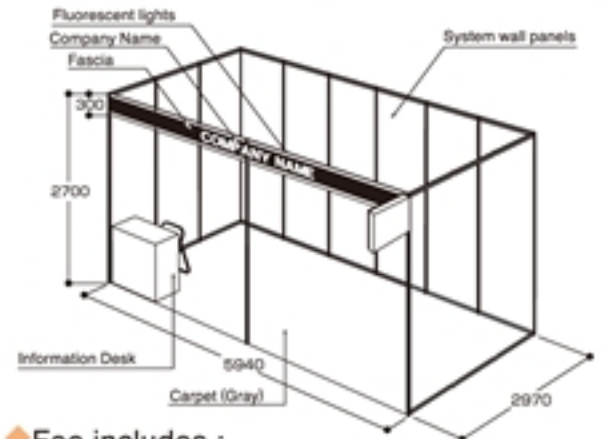

Fee includes :

- System wall panels
- Fascia
- Company name
- Carpet (Gray)
- Four fluorescent lights (40W)
- 300W main electrical power supply
- One power outlet
- One information desk
- One folding chair
- Booth number plate

Contact organizer for booth fee for 3 to 4 packaged booth units.

Challenge Booth

(2m×2m=4m²)
Contact Organizer for details.

Fee for corner space

(for exhibitors using only a booth unit)
+ JPY 50,000 (Tax excluded)
Corner booth unit is promised.

Fee for three-side open booth

(booths with 4 booth units)

+ JPY 60,000 (Tax excluded)

Height limit

Number of booth units	Height
1-4 booth units	2,700mm
5 booth units or more	4,500mm (set back 1m)
Challenge Booth	2,300mm

※Price does not include consumer tax. ※System fixture poles are aluminum painted black.

▶ FAX:+81-3-3433-7860 ▶ E-mail:nif2014@nif.or.jp

<input type="checkbox"/> We export to Japan	<input type="checkbox"/> We used to export to Japan	<input type="checkbox"/> We have never export to Japan before
<input type="checkbox"/> Others _____		
Company		
Address		
Depart.	Position	
Name	<input type="checkbox"/> Mr. <input type="checkbox"/> Ms.	
TEL	FAX	
E-mail		
Write any requests if any.		

NIF Nippon Interior Fabrics Association

6F, Fukuda Bldg., 2-3-23, Hamamatsucho, Minato-ku, Tokyo 105-0013 Japan

TEL:+81-3-3433-4521 FAX:+81-3-3433-7860 e-mail:nif2014@nif.or.jp

<http://www.japantex.jp/english>

FAX:+81-3-3433-7860

Deadline of application : June 30 (Mon), 2014

The 33rd
JAPANTEX2014
 INTERIOR TREND SHOW

Application Form

To:

Nippon Interior Fabrics Association

6F. Fukuda Bldg., 2-3-23, Hamamatsucho, Minato-ku, Tokyo 105-0013 Japan

TEL: +81-3-3433-4521 FAX:+81-3-3433-7860

Please fill in the below and send the form by FAX.

We are applying for The 33rd JAPANTEX2014 INTERIOR TREND SHOW as follows:

Head Office

Company Name			
Address			
TEL		FAX	

Contact Person

Company Name			
Name		Dept.	
Address			
TEL		FAX	
Email		URL	

Space	Exhibit Fee(include 8% tax)	Number of booth units	Subtotal
Basic booth / Raw space only (1-4 booth units) / (5 booth units or more)	JPY 367,200	× ()	JPY
Packaged booth (1-4 booth units)	1 booth units JPY 441,720		JPY
	2 booth units JPY 854,280		JPY
	3 booth units JPY 1,264,680		JPY
	4 booth units JPY 1,672,920		JPY
Fee for corner space (Booth with one booth unit)	JPY 54,000		JPY
Fee for three-side open booth (Booths with 4 booth units)	JPY 64,800		JPY
Total			JPY

Exhibiting Item / Explanation of Items to be displayed

The information contained on this application form will be retained by Nippon Interior Fabrics Association for various announcements, etc. regarding future editions of JAPANTEX. Please contact Nippon Interior Fabrics Association if use of this information is objectionable.

Date

Signature

JAPANTEX2014 General Exhibition Rules

1 Application to Exhibit

Those who wish to join the Exhibition are asked to submit to Nippon Interior Fabrics Association by fax, the application form in accordance with the application procedure described in the said form after agreeing to observe these exhibition rules.

2 Payment of Exhibition Fee

Exhibitors shall pay their full Exhibition Fee by the date specified in the Exhibition Fee Invoice. If the payment is not confirmed by the organizer by the specified date, the organizer has the right to cancel the exhibitor's application.

3 Alteration and Cancellation of Application

Any cancellation or alteration (reduction) in the size of exhibit space must be submitted in writing expressing the reason. Cancellations or alterations made after the application has been accepted are subject to the following fees (calculated as to date written notification received) :

From July 10 (Thu), 2014	100% of the exhibition fee
--------------------------	----------------------------

Any exhibitor who fails to pay the amount equal to that set forth in paragraph above of this article at the time of alteration or cancellation shall pay said amount immediately.

If the sum paid at the time of alteration or cancellation exceeds the relevant amount set forth above, the organizer shall refund the excess amount to the exhibitor.

4 Prohibition of Booth Subleasing

Exhibitors are prohibited to sublease, sell, exchange, or assign their booth without the organizer's specific approval.

5 Booth Allocation

Booth allocation shall be determined by the organizer. Exhibitors cannot object to the allocation once it is determined. The organizer reserves the right to change the booth allocation after announcement. If any exhibitor wishes to cancel its exhibit due to dissatisfaction with the booth allocation, the normal procedure for cancellation in payment of the prescribed cancellation fee will be required. The exhibitor cannot claim for compensation due to change of booth allocation.

6 Use of Booth

- (1) All publicity and sales activities by exhibitors must be performed within their own booth. Activities using the areas outside the booth shall be prohibited. In conducting publicity activities, exhibitors will be responsible for not causing congestion of the aisles around their booth.
- (2) Where booths are adjacent to each other, exhibitors shall agree not to arrange their booth displays or decorations in such manner as to interfere with the adjacent booths. Should any exhibitor of the adjacent booth make a claim, the organizer will determine whether it is necessary to change the booth arrangement in view of management of the exhibition. If the organizer determines it to be necessary, the exhibitor must comply with the decision and change the booth arrangement.
- (3) The organizer reserves the right to restrict displays that are considered to have problems due to their sound, operational methods, materials, or any other reasons and to ban or remove exhibits not suitable for the purpose of the exhibition from the viewpoint of the organizer.

7 Management of Exhibits and Indemnity

Individual exhibitors shall take full responsibility for the management and security /safety of exhibits and activities held within their booth, and the organizer shall be indemnified and held harmless from and against any losses or damages arising out of any causes whatsoever.

8 Application Termination

The organizer may terminate the exhibition application in case the exhibitor falls under any of the following cases:

- the Exhibition Fee has not been paid by the specified date;
- the Exhibitor violates the provisions of articles 6 concerning the use of booth, etc. and does not obey the instructions issued by the Organizer regarding correction thereof;
- any other cases in which serious trouble is deemed likely to affect the normal and smooth management of the exhibition.

9 Compensation for Damages

Exhibitors shall compensate damages to the facilities of the site or the building of the exhibition, or bodily injuries due to or arising from negligence of fault on their own part or by their agents.

10 Cancellation of the Exhibition

The organizer may postpone or cancel the Exhibition because of natural disasters such as earthquake, fire, etc. or any causes beyond its control. If the Exhibition is cancelled, the Exhibition Fee will be refunded to each exhibitor after deducting costs incurred. Other than such refund, no other compensation will be provided by the organizer.

11 Observance of the Rules

Exhibitors shall deem a series of regulations set forth by the organizer as part of these Exhibition Rules, and agree to observe them. Moreover, exhibitors shall understand that all said rules and regulations are intended to protect the benefit and well-being of the exhibition and agree to abide by them.

12 Copyright Protection

If product designs or textile patterns are copied illegally, they can not be displayed.

13 Protection of novelty (invention)

Inventions in articles on display in the JAPANTEX2014 (excluding those which have become public being announced on the Japanese and foreign patent gazettes) are eligible for application of the provision concerning exception to lack of novelty of invention (Patent Law). In addition, exhibitors of articles on display in the JAPANTEX2014 are entitled to claim the special provisions concerning time of filing of application for trademark (Trademark Law).

14 Jurisdiction

In case any disputes arise out of or in connection with the exhibit contract, the Tokyo District Court in Japan shall have the sole and exclusive jurisdiction.